

# DOSING & SCREENING MACHINE DM30 EASY CLEAN

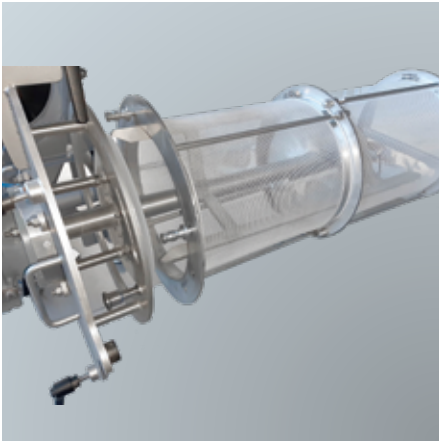

- All-in-One - Dosing system & Centrifugal screener
- Hygienic Design

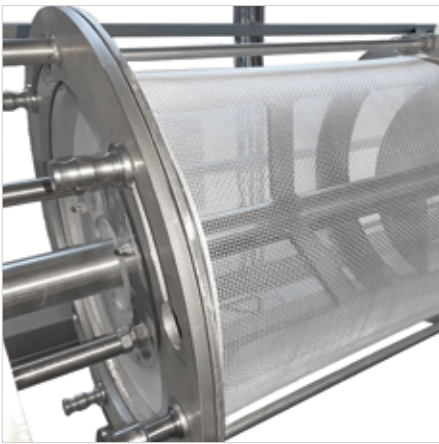
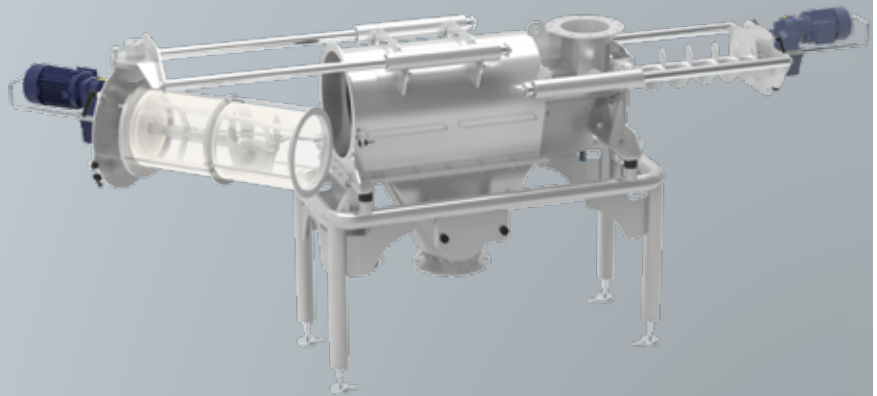

Ergonomic fast & easy  
cleaning with  
retractable screen and  
dosing screw



## Dosing & Screening machine DM30 Easy Clean:

**All-in-One:** Metering and sieving unit are combined. This way you save space and operating costs.

**Easy inspection, fast cleaning:** The metering and sieving unit can be easily pulled out for inspection thanks to the guided pull-out device: This allows a precise inspection of the entire interior and product chamber. If the screen basket needs to be changed, this can be done quickly and conveniently. The same applies to cleaning the machine.

**Hygienic Design:** The DM30 Easy Clean follows the principles of Hygienic Design. No compromise on quality and consequently reduced costs on downtime for cleaning and energy. The DM30 Easy Clean is made of stainless steel, AISI 304.

**Shaft sealing by means of monitored air flushing:** Monitoring ensures safe and low-maintenance operation.

### Design:

- Stainless steel construction complete with sturdy end plates
- Rotor shaft with paddle assembly and dosing screw
- Shaft sealing rings with monitored air purging
- Removable front plate including clamping lever and safety switch
- Including tilting mechanism
- Pull-out device for rotor shaft, screen basket and dosing screw
- Tilting mechanism for screening unit
- Certified according to ATEX Directive 2014/34/EU. Suitable for installation in zone 22.

### Output:

- Depending on product properties and mesh width
- 5,000 kg/h to 20,000 kg/h
- Mesh width 600 - 3,300  $\mu$ m
- Screen basket material: Nitex

### Scope of delivery:

- 1 Dosing & Screening machine DM30 Easy Clean
- 1 Air purge fitting with flow monitoring
- 1 Collection tray to collect product residue
- 1 Support frame mounted on anti-vibration mounts
- 1 Overflow NW150
- 1 Bagging spout with sack strap DM273 DN150
- 1 Connecting set for the intake pipe
- 1 Discharge hopper DN250

### Option:

- Spare Nitex sieve screen
- Sieve box made of perforated metal plate
- Polished surface finish on the inside of discharge hopper
- Pipe magnet at inlet
- Gear motors made of stainless steel
- Screen basket made of stainless steel



Here you can find more information about the Dosing & Screening machine DM30 Easy Clean

Daxner Headquarters AUSTRIA  
Worldwide Powder Handling  
Vogelweiderstraße 41  
4600 Wels/Austria

+43 / 7242 / 44 227-0  
office@daxner.com

Daxner GERMANY  
Bakery & Liquids Division

Daxner USA  
Daxner UK  
Daxner SOUTH-EAST ASIA  
Daxner LATAM



www.daxner.com